

5/26/2017 13:13 C:\Users\j25c0\Desktop\BD.2.7.2.0.09 - Roadside Traffic Signs 09.dgn

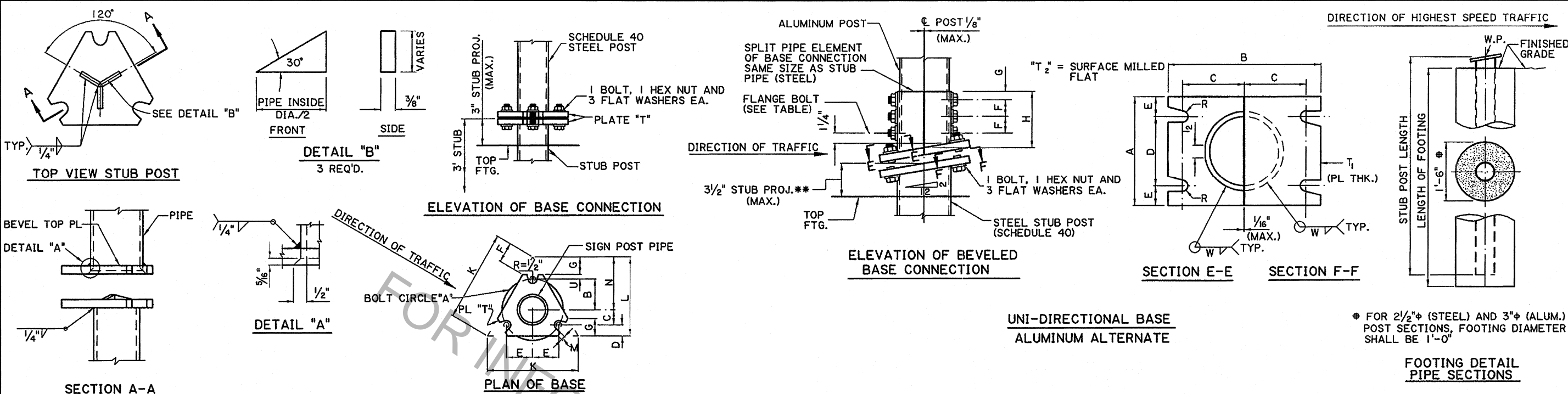

**STEEL MULTI-DIRECTIONAL BASE CONNECTION DATA**

NOMINAL PIPE SIZE	BOLT SIZE & TORQUE	WELD SIZE	T	Y	A	B	C	D	E	F	G	K	L	M	N	U
2 1/2" OR 3 1/2" DIA.	5/8" T=226	3/8"	5/8"	7"	7"	3 1/2"	1 3/4"	1 1/4"	3"	2 5/16"	2"	10 3/8"	9"	1/2"	6"	1/2"

FOR STUB POST LENGTH & FOOTING DIMENSION SEE TABLE BELOW AND FOOTING DETAIL. ° TORQUE IN INCH-LBS., BOLTS ARE HIGH STRENGTH

NOTE: MULTI-DIRECTIONAL BREAK-AWAY FEATURE IS TO BE USED ONLY AT LOCATIONS WHERE SIGN IS LIKELY TO BE STRUCK FROM MORE THAN ONE DIRECTION.

**MULTI-DIRECTIONAL BASE**  
SINGLE STEEL POST ONLY

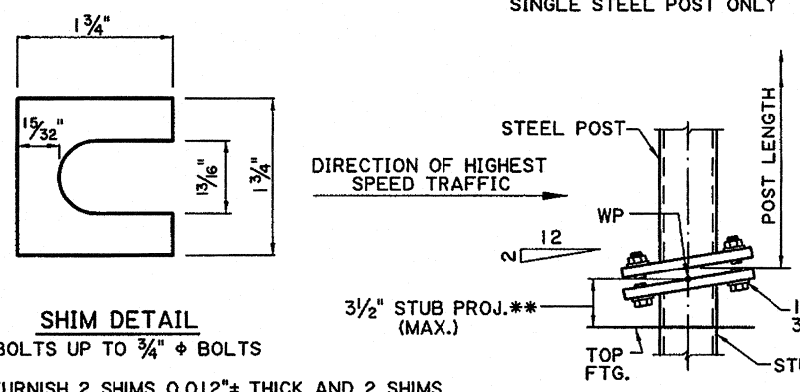

\*\*TO MAINTAIN CORRECT STUB PROJECTION, RECESS CONCRETE AS NECESSARY FOR BOLT INSTALLATION (RECESS SHALL BE SHAPED TO DRAIN)

**ELEVATION OF BEVELED BASE CONNECTION**

**PLAN BASE PLATE AND PIPE POST**

**UNI-DIRECTIONAL BASE STEEL ALTERNATE**

TYPE POST	DIMENSION SECTION (INCH)	BOLT SIZE & TORQUE LIMITS	UNI-DIRECTIONAL BASE CONNECTION DATA													FOOTING DATA				
			A	B	C	D	E	F	G	H	T <sub>1</sub>	T <sub>2</sub>	W	R	FLANGE BOLTS	STUB LTH.	LTH. OF FTG.	STEEL STUB POST	CU. YD. CONC.	
STEEL SCH. 40	2 1/2" φ	1/2" φ T=95-142	4 1/2	6 1/2	3/4	2 1/2	1	—	—	—	—	3/4	—	5/16	7/32	—	36	36	2 1/2" φ	0.09
	3 1/2" φ	1/2" φ T=95-142	5 1/2	7 3/4	3/4	3 1/2	1	—	—	—	—	1	—	3/8	7/32	—	36	36	3 1/2" φ	0.20
	5" φ	5/8" φ T=226-345	6 1/2	9 3/4	3/4	4	1 1/4	—	—	—	—	1 1/4	—	7/16	11/32	—	48	48	5" φ	0.26
	6" φ	3/4" φ T=369-554	8	11	7/8	5 1/2	1 1/4	—	—	—	—	1 1/4	—	3/8	13/32	—	60	60	6" φ	0.33
ALUM. SCH. 40 (TUBE)	3" φ x 3/16"	1/2" φ T=95-142	5	8	3	3	1	1 1/2	1	5 5/8	3/4	1	1/4	7/32	1/2" φ	36	36	3" φ	0.09	
	4" φ x 3/16"	1/2" φ T=95-142	6	9 1/2	4	4	1	1 1/2	1	5 5/8	3/4	1	3/8	7/32	1/2" φ	36	36	4" φ	0.20	
	6" φ x 1/4"	5/8" φ T=226-345	8	11	4 1/2	5 1/2	1 1/4	2	1	6 3/4	3/4	1 1/4	7/16	11/32	5/8" φ	48	48	6" φ	0.26	

\* ALL BOLTS SHALL HAVE A MINIMUM OF 3 THREADS BEYOND THE NUT. BOLT TORQUE LIMITS IN INCH POUNDS. (THE HIGH STRENGTH BOLTS AT THE BASE CONNECTION SHOULD BE TORQUED WITHIN THE LIMITS SPECIFIED, HOWEVER, THE LOWER LIMIT IS DESIRABLE). FOR NON-BREAKAWAY USE TORQUE LIMITS GIVEN IN THE STANDARD SPECIFICATIONS.

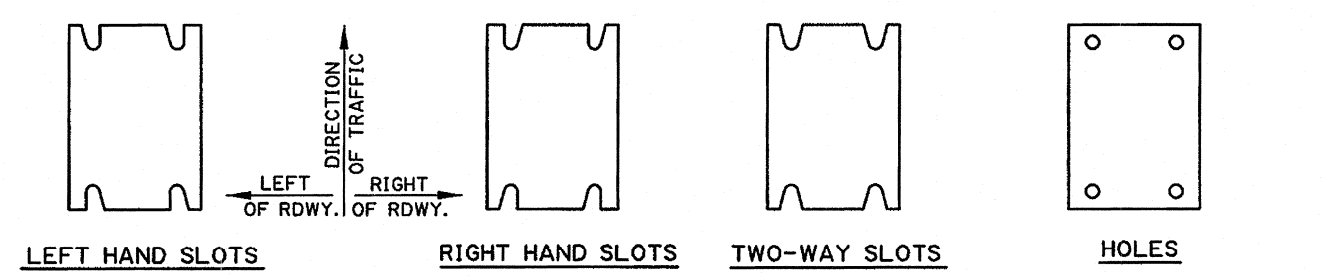

**ORIENTATION AND USE OF SLOTS AND HOLES**

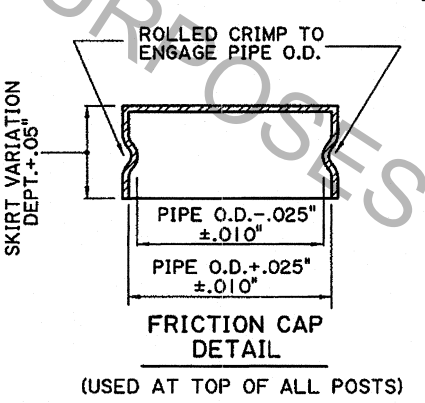

**PROCEDURE FOR ASSEMBLY OF BASE CONNECTION:**

SPECIAL CARE SHALL BE TAKEN TO SET THE BASE PLUM TO AVOID EXCESSIVE SHIMMING AT THE BREAK-AWAY FEATURE AFTER FINAL INSTALLATION. EXCESSIVE SHIMMING COULD IMPAIR THE BREAK-AWAY FEATURE FOR WHICH THIS INSTALLATION WAS DESIGNED. SHIM PACKS SHOWN ON THIS DRAWING SHOULD BE SUFFICIENT TO ALLOW FOR NORMAL MISALIGNMENT.

1. BASE SHALL BE ALIGNED AND SET PLUM BEFORE OR IMMEDIATELY AFTER POURING CONCRETE FOOTING.
2. H.S. BOLTS IN BASE PLATE SHALL BE TIGHTENED TO THE PRESCRIBED TORQUE. CARE SHALL BE TAKEN TO AVOID OVERTIGHTING.

**FRICTION CAPS:**

CAPS MAY BE MANUFACTURED FROM EITHER HOT ROLLED OR COLD ROLLED STEEL SHEETS. FOR PIPE SIZES 3 1/2" AND SMALLER THE MINIMUM SHEET METAL THICKNESS SHALL BE 24 GAUGE. THE RIM EDGES SHALL BE REASONABLY STRAIGHT AND SMOOTH. CAPS SHALL BE SIZED AND FORMED IN SUCH A MANNER AS TO PRODUCE A DRIVE-ON FRICTION FIT AND HAVE NO TENDENCY TO ROCK WHEN SEATED ON THE PIPE. THE DEPTH SHALL BE SUFFICIENT TO GIVE POSITIVE PROTECTION AGAINST ENTRANCE OF RAINWATER. THEY SHALL BE FREE OF SHARP CREASES OR INDENTATIONS AND SHOW NO EVIDENCE OF METAL FRACTURE. CAPS SHALL HAVE AN ELECTRODEPOSITED COATING OF ZINC IN ACCORDANCE WITH THE REQUIREMENTS OF A.S.T.M. SPECIFICATION B633 SC4, TYPE 1.

THIS SHEET TO BE USED WITH WIND LOAD MAP AND GENERAL NOTE SHEET.

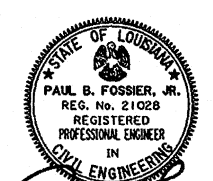

*Paul B. Fossier, Jr.* 8/31/00

SHEET NUMBER: \_\_\_\_\_

DESIGNED BY: J.C. PORTER  
CHECKED BY: A. BRIDGES  
DATE: JULY 2010

DRAWN BY: E. DEARMOND  
CHECKED BY: \_\_\_\_\_  
DATE: \_\_\_\_\_

PROJECT: \_\_\_\_\_

STATE PROJECT: \_\_\_\_\_

PARISH: \_\_\_\_\_

FEDERAL PROJECT: \_\_\_\_\_

DATE: JULY 2010

SHEET: 9 OF 11

REVISION DESCRIPTION: \_\_\_\_\_

NO. \_\_\_\_\_

DATE: 12-02-16 UPDATE FOR 2016 SPECIFICATIONS

BY: K.M.B.

ROADSIDE MOUNTED SUPPORT DETAIL TYPE A & B SIGNS

BD.2.7.2.0.9 - ROADSIDE TRAFFIC SIGNS

BRIDGE AND STRUCTURAL DESIGN